

OPERATING INSTRUCTIONS MANUAL
(Please retain for future reference)
For
FVO-1000TR INDIRECT FIRED HEATER TRAILER



CERTIFIED FOR USE IN CANADA AND U.S.A.
As per CSA B140.8 Portable Oil Fired Heaters / CSA B140.0 2003 Oil Burning Equipment
UL733 Oil Fired Air Heaters
Construction Heaters Unattended Type.

FLAGRO INDUSTRIES LIMITED
ST. CATHARINES, ONTARIO
CANADA

GENERAL HAZARD WARNING:

FAILURE TO COMPLY WITH THE PRECAUTIONS AND INSTRUCTIONS PROVIDED WITH THIS HEATER, CAN RESULT IN DEATH, SERIOUS BODILY INJURY AND PROPERTY LOSS OR DAMAGE FROM HAZARDS OF FIRE, EXPLOSION, BURN, ASPHYXIATION, CARBON MONOXIDE POISONING, AND/OR ELECTRICAL SHOCK.

ONLY PERSONS WHO CAN UNDERSTAND AND FOLLOW THE INSTRUCTIONS SHOULD USE OR SERVICE THIS HEATER.

IF YOU NEED ASSISTANCE OR HEATER INFORMATION SUCH AS AN INSTRUCTIONS MANUAL, LABELS, ETC. CONTACT THE MANUFACTURER.

WARNING:

FIRE, BURN, INHALATION, AND EXPLOSION HAZARD. KEEP SOLID COMBUSTIBLES, SUCH AS BUILDING MATERIALS, PAPER OR CARDBOARD, A SAFE DISTANCE AWAY FROM THE HEATER AS RECOMMENDED BY THE INSTRUCTIONS. NEVER USE THE HEATER IN SPACES WHICH DO OR MAY CONTAIN VOLATILE OR AIRBORNE COMBUSTIBLES, OR PRODUCTS SUCH AS GASOLINE, SOLVENTS, PAINT THINNER, DUST PARTICLES OR UNKNOWN CHEMICALS.

This heater is designed and approved for use as a construction heater under CSA B140.8 Portable Oil Fired Heaters / CSA B140.0 2003 Oil Burning Equipment, UL733 Oil Fired Air Heaters

We cannot anticipate every use which may be made of our heaters. CHECK WITH YOU LOCAL FIRE SAFETY AUTHORITY IF YOU HAVE QUESTIONS ABOUT APPLICATIONS.

Other standards govern the use of fuel gases and heat producing products in specific applications. Your local authority can advise you about these

TABLE OF CONTENTS

Trailer Check List.....	4
Towing Instructions.....	5
FVO-1000TR Set-up Procedure.....	6
Set-up Procedure (High Altitude).....	7,8,9
Nozzle Placement.....	10
Specifications.....	11
Trailer Preparation.....	12,13
Heater Start up.....	14
Troubleshooting.....	15
Heater Maintenance.....	16
Feeler Gauge.....	17
Burner Wiring Diagram.....	18
Electrode & Oil Line.....	19
Trailer Wiring Schematic.....	20
Parts List.....	21,22,23

TRAILER CHECK LIST

**PLEASE PERFORM THE FOLLOWING STEPS TO YOUR
FVO-1000TR HEATER TRAILER TO ENSURE PROPER OPERATION.**

- **Visually inspect outside & inside of trailer to ensure all instructions and decals are in place and legible.**
- **Inspect the tires to ensure road worthy and have proper inflation.**
- **Inspect hitch assembly and safety tow chains.**
- **Inspect jack assembly to make sure it operates properly.**
- **Make sure all trailer cabinet doors are closed before attempting to relocate trailer.**
- **Check lug nuts and torque to 80-90 ft. lbs. Lug nuts should be re-torqued every 100 miles.**
- **Check oil, fuel and coolant levels on genset.**
- **Make sure brake & signal lights on trailer are completely operational.**
- **Make sure the battery is fully charged and the terminals are tight.**
- **Start engine and heaters to ensure proper operation.**
- **Review engine manual for maintenance requirements.**

TOWING INSTRUCTIONS

Before towing the FVO-1000TR, please make sure you go over the following steps to ensure your trailer is road ready.



- 1. Hitch is securely attached to towing vehicle.**
- 2. Safety chains are securely attached to towing vehicle.**
- 3. Front jack is completely retracted.**
- 4. Check all tires ensure they have adequate air pressure.**
- 5. Make sure all ducting is removed from heaters and stored.**
- 6. All doors are closed and secure.**
- 7. Taillights are connected and operating.**

FVO-1000TR SETUP PROCEDURE

The two FVOHC-400 heaters in the trailer need to be tested and set up before every operation. Proper combustion must be achieved using a certified combustion analyzer and smoke gun tester to ensure optimum set up. The air adjustment should be made to achieve a maximum of 10% CO₂ and No. 1 or “trace” smoke. (Bacharach Scale)

SETTING THE AIR ADJUSTMENT PLATE

A) Regulation of the combustion air flow is made by adjustment of the manual AIR ADJUSTMENT PLATE (1) after loosening the FIXING SCREWS (2 & 3). The initial setting of the air adjustment plate is set to 4.5 at the factory.

B) The proper number on the manual AIR ADJUSTMENT PLATE (1) should line up with the SETTING INDICATOR (4) on the fan housing cover. Once set, the air adjustment plate should be secured in place by tightening SCREWS 2 and 3.

C) The final position of the air adjustment plate will vary on each installation. Use instruments to establish the proper settings for maximum CO₂ and a smoke reading of zero.

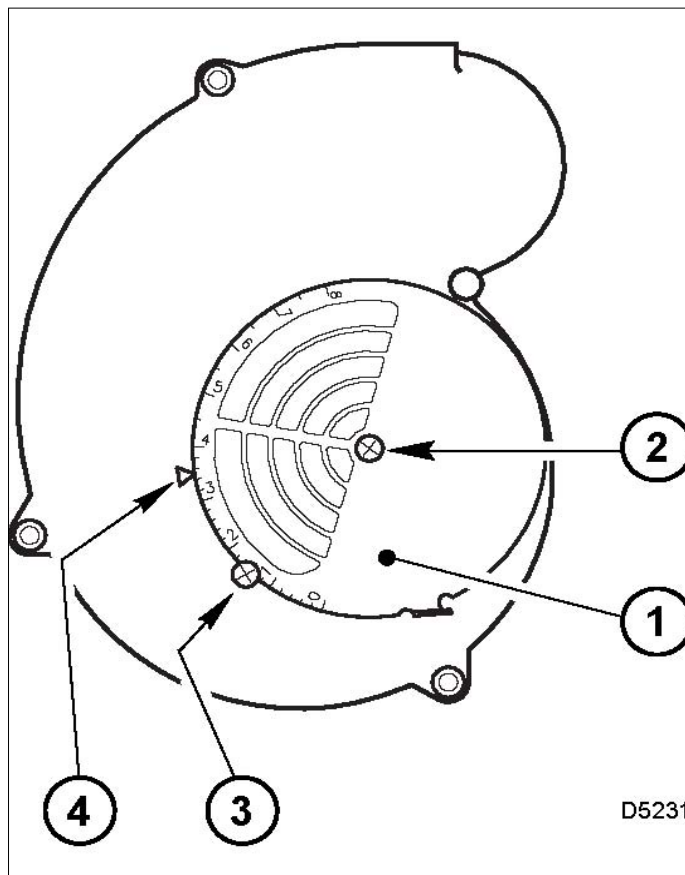

NOTE: Variations in flue gas, smoke, CO₂ and temperature readings may be experienced when the burner cover is put in place. Therefore, the burner cover **must** be in place when making the final combustion instrument readings, to ensure proper test results.

SETUP PROCEDURE (HIGH ALTITUDE)

When the FVO-1000TR is required to operate over 2000 feet above sea level there will be necessary adjustments needed to burn efficiently with thinner air. Please review the following chart as a starting point; please note that a combustion analyzer & smoke gun will be required to achieve optimum set up.

ACTUAL FIRING RATE +/- 5%	NOZZLE SIZE	PUMP PRESSURE	TURBULATOR SETTING	AIR DAMPER SETTING	ALTITUDE RANGE
2.11 GPH	1.75 X 60W	145 PSI	2.5	3.1	OVER 7000FT
2.41 GPH	2.00 X 60W	145 PSI	3.5	3.4	3500-6900FT
2.61 GPH	2.00 X 60W	170 PSI	5.0	4.5	0-3500FT

Please refer to the Air adjustment plate diagram on page 6, the turbulator diagram at the bottom of this page & the nozzle replacement diagram on page 8.

NOTE: The burners are equipped with a 2.00 X 60W nozzle, due to the increase density of oil/diesel fuel at colder temperatures.

TURBULATOR SETTING

- A) Loosen NUT (1), then turn SCREW (2) until the INDEX MARKER (3) is aligned with the correct index number as per the Burner Set-up chart above.
- B) Retighten the RETAINING NUT (1)

NOTE: Zero and five are scale indicators only. From left to right, the first line is 5 and the last line 0.

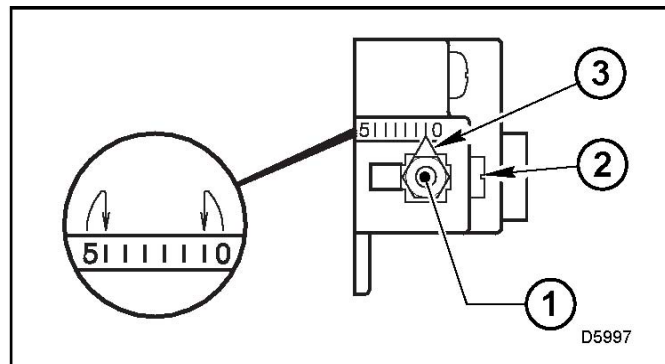

INSERTION / REMOVAL OF DRAWER ASSEMBLY

- A)** To remove drawer assembly, loosen SCREW (3), then unplug CONTROL BOX (1) by carefully pulling it back and then up.
- B)** Remove the AIR TUBE COVER PLATE (5) by loosening the two retaining SCREWS (4).
- C)** Loosen SCREW (2), and then slide the complete drawer assembly out of the combustion head as shown.
- D)** To insert drawer assembly, reverse the procedure in items A to C above, and then attach fuel line to the pump.

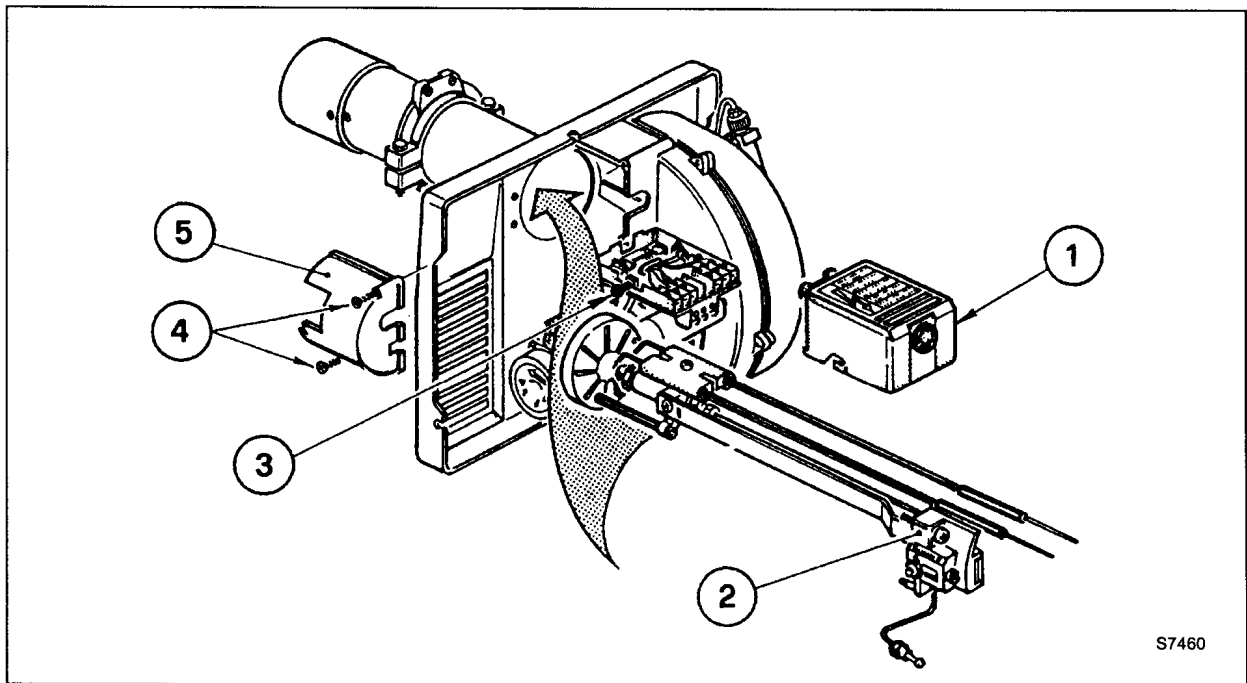

S7460

NOZZLE PLACEMENT

- A)** Remove the NOZZLE ADAPTER (2) from the DRAWER ASSEMBLY by loosening the SCREW (1).

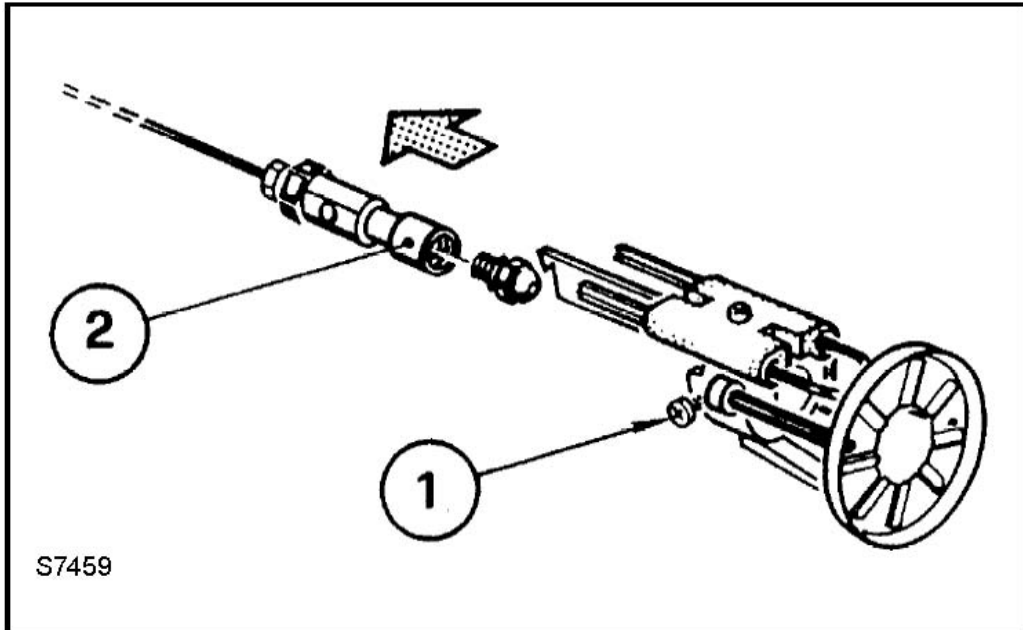

- B)** Insert the proper NOZZLE into the NOZZLE ADAPTER and tighten securely (Do not over tighten).
- C)** Replace adapter, with nozzle installed, into drawer assembly and secure with screw (1).

SPECIFICATIONS

Model	FVO-1000TR
Input	390,000 BTU x 2 @ 2.61 GPH
Engine	Yanmar or Kubota Liquid Cooled Diesel Electric start/ glow plugs Battery charging alternator Heavy duty Radiator & Air Cleaner Remote Oil Drain
Generator.....	8 kw @ 1800 rpm (15.3 HP) Single phase-120V Instrument panel including Hour Meter
Fuel	No.1, No. 2, Diesel
Fuel Pressure	170 psi @ 0-2000 ft
Nozzle	2.00 x 60W (Delavan) @ 0-2000 ft
Fuel Tank	1,132 Liters / 300 Gallons Heavy duty fuel sight gauge 2" Fuel inlet nozzle
Power Tool Outlet	1 x 15 Amp GFI Outlet
Ignition	Direct Spark Ignition
Fan Motor.....	1-1/2 HP @ 3450 RPM
Air Circulation	3000 CFM
Fuel Consumption	6.07 GPH at full load
Dimensions.....	Height-7ft, Length-15ft, Width-7ft 4 inches
Weight.....	4,300 lbs (Empty)
Approvals	cWHus listed (Heaters) CSA/ Entela approved (Engine/Generator) DOT approved trailer

TRAILER PREPARATION FOR START-UP

PLEASE REVIEW TRAILER CHECKLIST, FVO-1000TR SETUP & GENERATOR MANUAL BEFOR PROCEEDING

**OPEN REAR GENERATOR
ACCESS DOORS**



**OPEN OUTLET DOOR &
ATTACH DUCTING TO
HEATERS**



**OPEN HEATER START UP
DOOR**



**INSPECT FUEL GAUGE FOR
SUFFICIENT LEVEL OF FUEL**



**MAKE SURE BATTERY LOCK
OUT IS TURNED OFF, AND
TURN KEY ON CONTROL
PANEL TO START**



HEATER START UP INSTRUCTIONS:

1. Be sure the "switch" is in the "OFF" position.
2. Start generator , verify heater inlet and outlet door are in the open position.
3. Move switch to "MANUAL" position for manual control.
4. Move switch to "THERMOSTAT" position for thermostatic control.

OR

Please Note:

1. If using Thermostat on unit, unit must be started in Thermostat position.
2. When changing between manual and thermostat operation, the heater must be left in the "OFF" position for 30 seconds to prevent the burner from locking out.
3. If the generator runs out of fuel, make sure the heater switch is in the "OFF" position before restarting generator, failure to do so may damage heater.

TO SHUT DOWN:

1. Move switch to "OFF" position.

NOTE: Fan will continue to operate after the burner shuts down. Once the unit cools down, the fan will stop.

Never pull power plug to shut unit down, if power plug is pulled ignition box may be damaged, and will not be covered under warranty.

IF HEATER FAILS TO START:

1. Press manual reset button at rear of burner. (Red button)
2. Check fuel level gauge for sufficient amount of fuel.
3. Make sure there are no air blocks in fuel lines or filter. Bleed lines if required.
4. Ensure power supply plug is connected properly.
5. Check for dirty fuel filter or blocked fuel supply line.
6. Check burner nozzle assembly.
7. Make sure the burner control box does not need to be reset.

NOTE: IF THE BURNER HAS BEEN RESET SEVERAL TIMES THERE MAY BE AN ACCUMULATION OF **FUEL** IN THE CHAMBER! DO NOT CONTINUE TO TRY AND START THE HEATER!

DRAIN FUEL FROM HEAT EXCHANGER USING DRAIN HOLE AT FRONT OF HEAT EXCHANGER FOR 15-20 MINUTES BEFORE ATTEMPTING TO RELIGHT. LET REMAINING EXCESS **FUEL** BURN OFF BEFORE CHECKING COMBUSTION OF UNIT.

SAFE OPERATION PRECAUTIONS:

1. Do not fill fuel tank while heater is operation.
2. Do not attempt to start heater if excess oil remains in the heat exchanger.
3. Use switch to shut down the heater. Do not try to shut down the heater by unplugging the electrical cord.
4. Do not plug anything other than the thermostat into the "Thermostat" plug.
5. Do not use any fuel other than those listed on rating plate.
6. Before removing any guards or performing any maintenance, be sure that the main power supply is disconnected.

MAINTENANCE:

1. **Every construction heater should be inspected before each use, and at least annually by a qualified service person. Incorrect maintenance may result in improper operation of the heater and serious injury could occur.**
2. The hose assemblies shall be visually inspected prior to each use of the heater. If it is evident there is excessive abrasion or wear, or the hose is cut, it must be replaced prior to the heater being put into operation. The replacement hose assembly shall be that specified by the manufacturer.
3. The flow of combustion and ventilation air must not be obstructed. Be sure to check the fan assembly and ensure that the motor and blade are operating properly.
4. Compressed air should be used to keep components free of dust and dirt build up. Note: Do not use the compressed air inside any piping or regulator components.
5. Change fuel filter insert (Part# FVO-418) once per month. Change fuel filter cartridge (Part# FVO-419) once every 6 months.
6. Change oil burner nozzle (Part# FV-435B (2.00 X 60) OR FV-435WC (1.75 X 60) once per year.
7. Fan Limit Switch (Part# FV-407A) should be replaced if the fan motor does not shut off after the heat exchanger has cooled down.
8. The High Limit Switches (Part# FV-406 & FV-437) should be checked each season. These limit switches will ensure the burner shuts down if the temperature exceeds 150° F at rear of unit and 250° F at the outlet.
9. Fuel tank should be drained on a regular basis by removing drain plug.
10. **CAUTION** – Do not have any source of ignition near the heater when draining tank.

NOTE: No.1 fuel oil or kerosene is recommended for temperatures below -10° C / 8° F.
11. Heat Exchanger should be cleaned if smokey conditions continue even after the air adjustments on the burner are made.

TEMPERATURE FEELER GAUGE ADJUSTMENT (ATTACHED TO FAN SWITCH)

The temperature feeler gauge is required to be always touching the heater exchanger.

The temperature feeler gauge controls the air flow over the fan switch, which eliminates any unnecessary fan cycling. The temperature feeler gauge can be adjusted for different outside temperatures, by rotating the location of the temperature feeler gauge holes. This will provide maximum performance of the unit in different applications.

If supply air is warm (-5°C , indoor application):

Turn the temperature feeler gauge so that the holes are parallel with the heat exchanger. This will help the fan switch to remain cool and not overheat. See following:

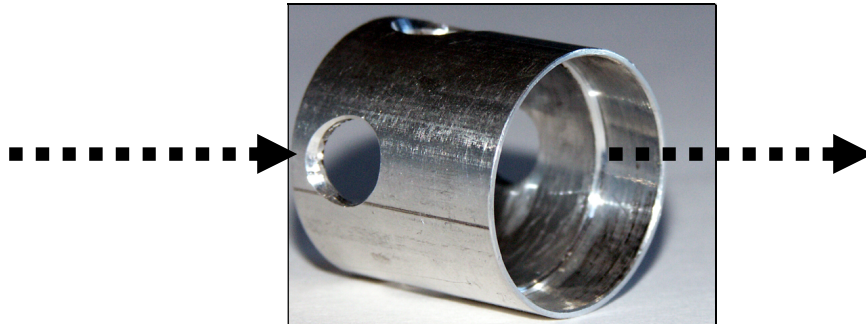

If supply air is cold (under -5°C):

Turn the temperature feeler gauge so that the holes are closed off as the air goes over the heat exchanger. This will reduce fan cycling and the unit from shutting down. See following:

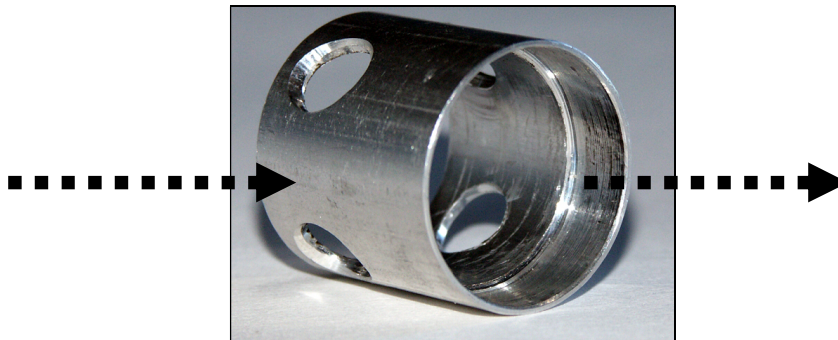

In extreme cold conditions, cover the holes on the temperature feeler gauge using foil tape or use part# FV-433B (solid feeler gauge). Ensure that the temperature feeler gauge is readjusted for warmer weather conditions. Failure to do so may result in burning out fan switches- not covered under warranty.

BURNER WIRING DIAGRAM

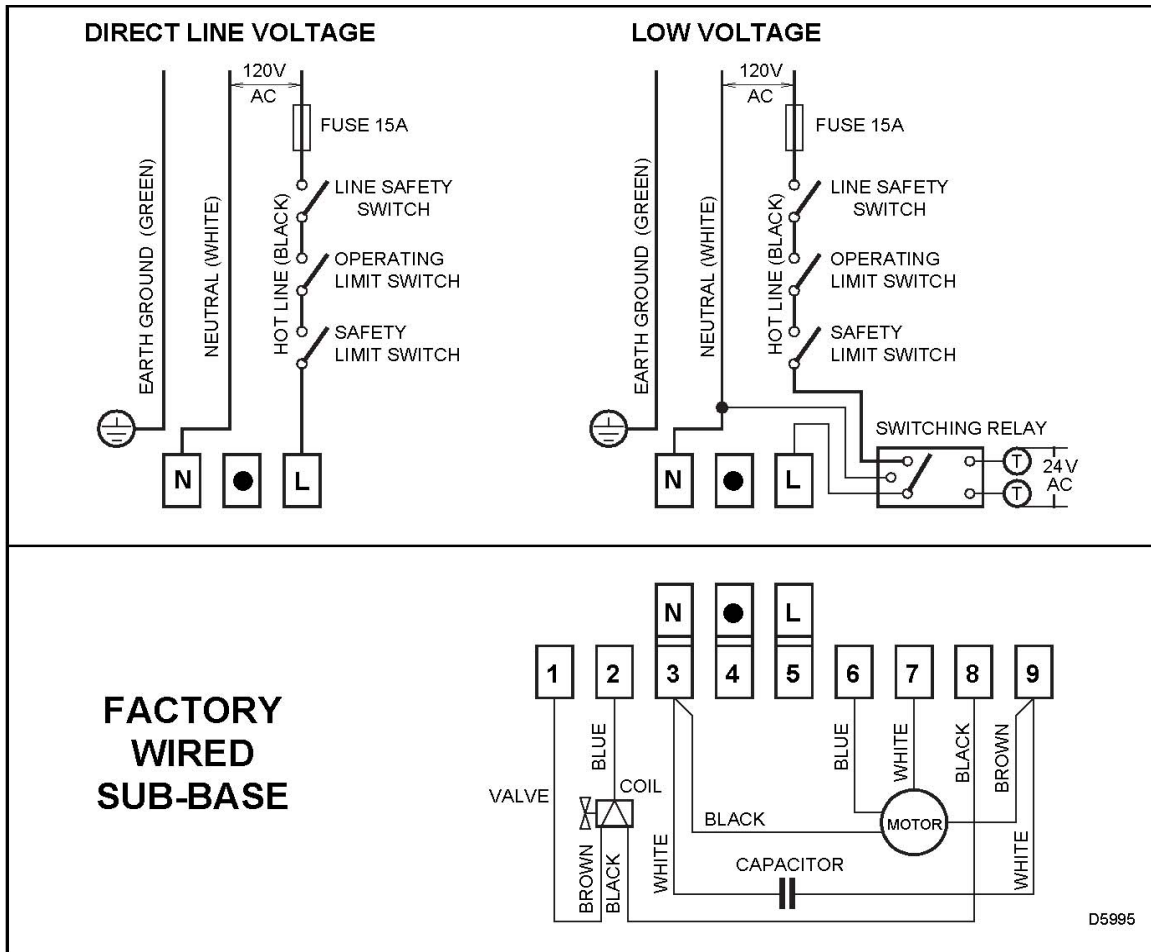

ELECTRICAL CONNECTIONS

It is advisable to leave the control box off the sub-base while completing the electrical connections to the burner.

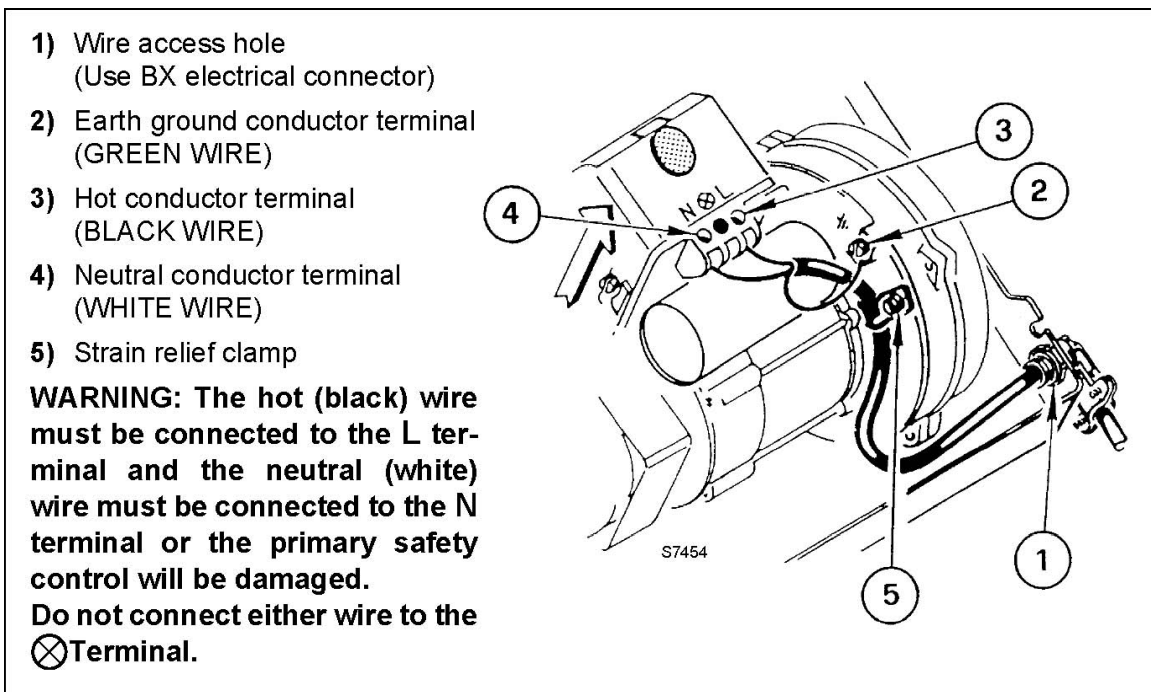

ELECTRODE SETTING

IMPORTANT:

THESE DIMENSIONS MUST BE OBSERVED AND VERIFIED.

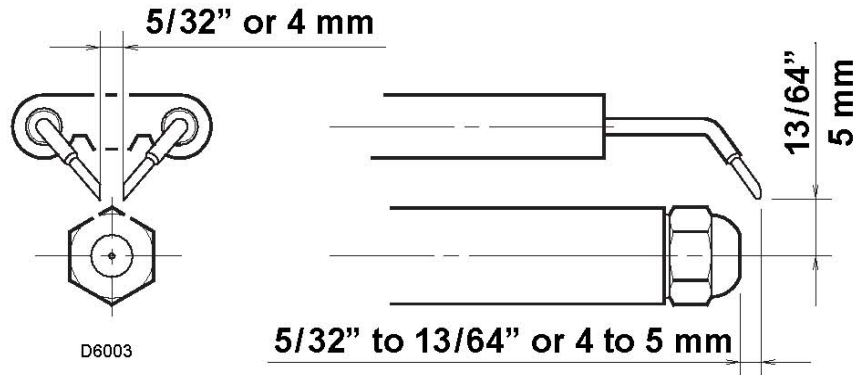

OIL LINE CONNECTIONS

Note: Pump pressure must be set at time of burner start-up. A pressure gauge is attached to the PRESSURE PORT (8) for pressure readings. Two PIPE CONNECTORS (5) are supplied with the burner for connection to either a single or a two-pipe system. Also supplied are two ADAPTORS (3), two female 1/4" NPT, to adapt oil lines to burner pipe connectors. All pump port threads are British Parallel Thread design. Direct connection of NPT threads to the pump will damage the pump body. Riello manometers and vacuum gauges do not require any adaptors, and can be safely connected to the pump ports. An NPT (metric) adapter must be used when connecting other gauge models.

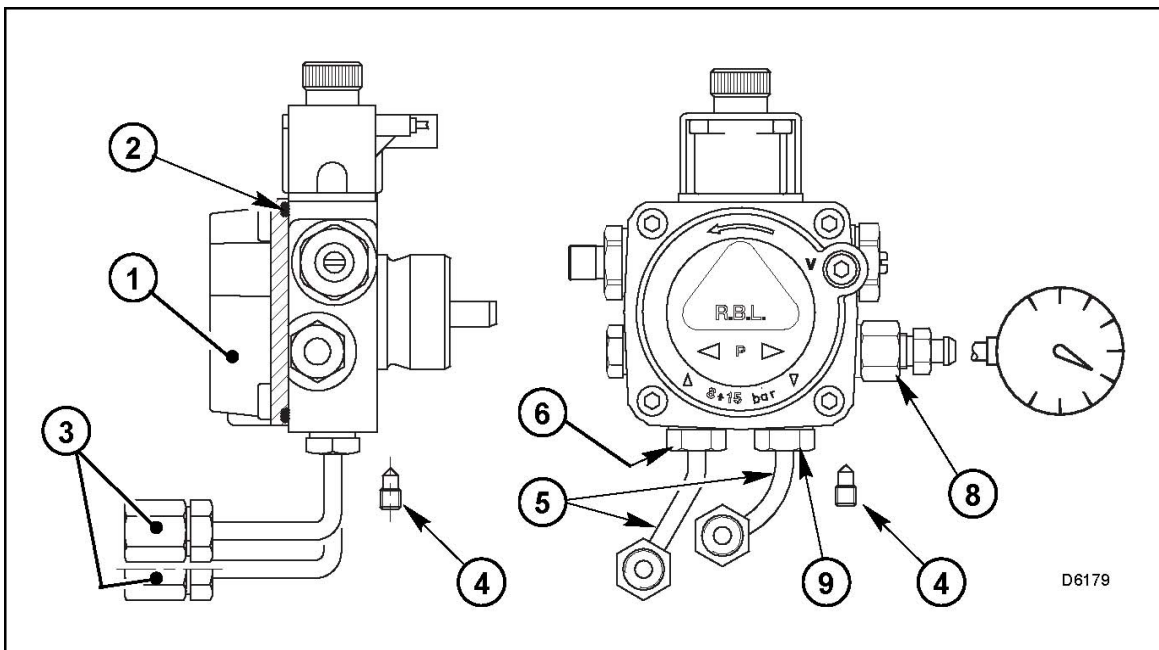

F-10 OIL FIRED BURNER - PARTS DIAGRAM

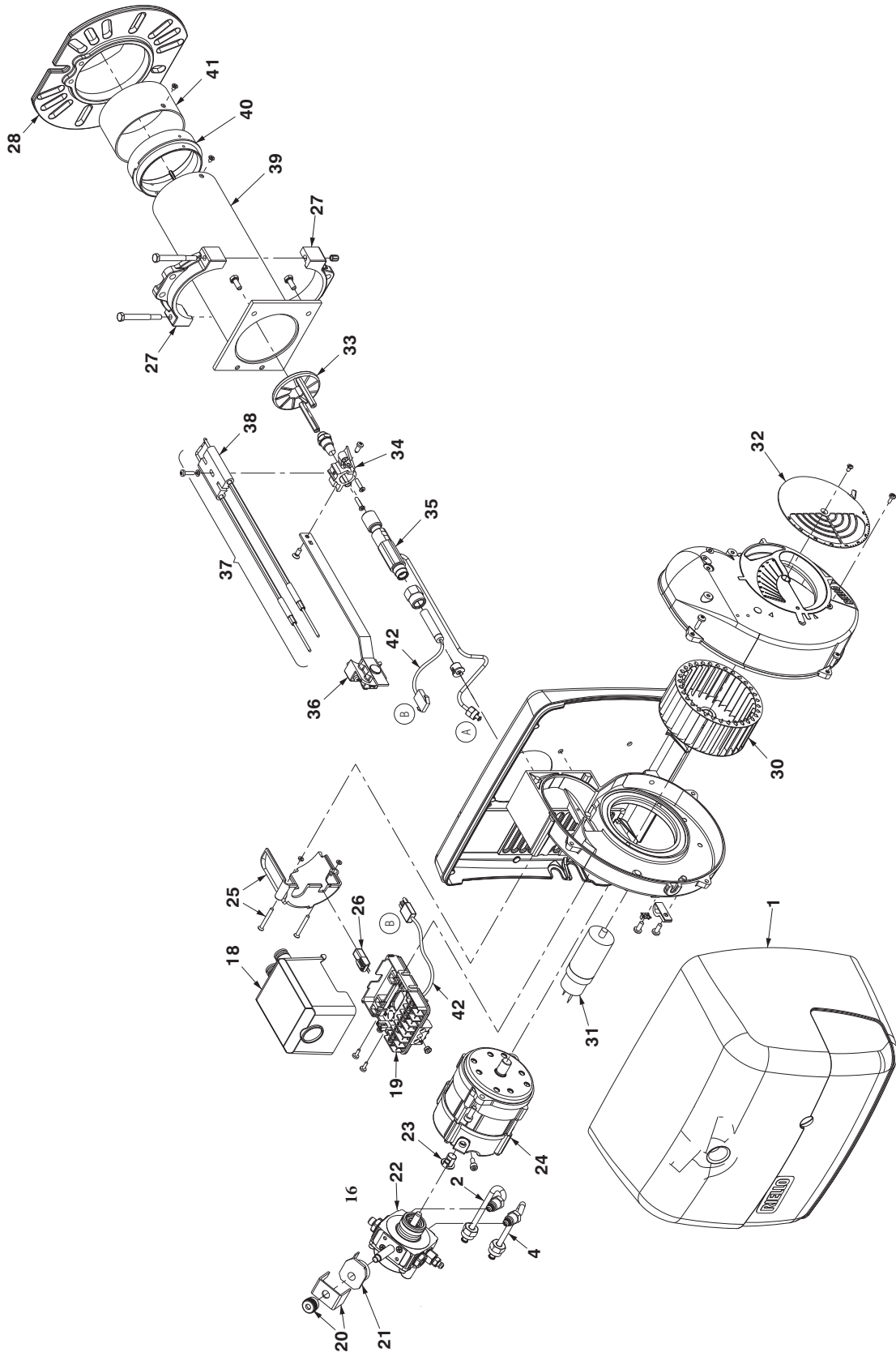

RIELLO BURNER F10 - PARTS LIST DIAGRAM		
N#	PART NUMBER	DESCRIPTION
1	FV-20136636-OIL	PLASTIC BURNER COVER C/W LABELS
2	FVO-3006992	SUPPLY LINE
4	FVO-3006993	RETURN LINE
16	FVO-3020076	PUMP ADAPTER FOR NOZZLE HOLDER FUEL LINE
18	FVO-C700-1029	IGNITION MODULE
19	FVO-3002278	SUB-BASE FOR IGNITION MODULE
20	FVO-3006553	COIL U-BRACKET C/W KNURLED NUT
21	FVO-3002279	PUMP COIL
22	FVO-20136488	BURNER PUMP
23	FVO-3000443	PUMP DRIVE KEY
24	FVO-C7001034	BURNER MOTOR
25	FVO-3007317	AIR TUBE COVER PLATE
26	FVO-20132573	PHOTO CELL
27	FVO-3005854	SEMI FLANGE
28	FVO-3005855	MOUNTING FLANGE
30	FV-3005788	BURNER FAN
31	FVO-3005844	BURNER CAPACITOR
32	FVO-3007205	AIR DAMPER
33	FVO-3006978	TURBULATOR DISC
34	FVO-3006966	ELECTRODE SUPPORT
35	FVO-20136639	NOZZLE HOLDER
36	FVO-3005889	REGULATOR ASSEMBLY
37	FVO-3005891	ELECTRODE ASSEMBLY
38	FVO-3005869	ELECTRODE PORCELAIN
39	FVO-3006982	BLAST TUBE
40	FVO-3006983	END CONE ADAPTER
41	FVO-3006984	END CONE
42	FVO-20136491	PREHEATER



26 Benfield Drive , St.Catharines Ontario Canada
905-685-4243

FVO-1000TR – PARTS LIST

HARDWARE

DOOR LATCH ASSEMBLY



FMA-2312

BOLT ON HINGE



FV-450TR

PUSH TO CLOSE



FV-443TR

LOCKING DOOR LATCH/ ROD



FV-465TR

BALL HITCH



FVO-437TR

PINTLE HITCH



FVO-438TR

SUPPORT JACK



FVO-435TR

EMERGENCY BREAKAWAY KIT



FV-EBK

LICENSE PLATE LIGHT



FVO-439TR

SAFETY CHAINS (set)



FVO-436TR

KILL SWITCH



FV-440TR-1

**VENT DEFLECTOR/
VENT PIPE
(2 PER TRAILER)**



FV-464TR/FV-463TR

TAILPIPE



FV-457TR

MUFFLER & FLEX PIPE



FV-458TR/FV-459TR

**OIL TANK CAP C/W CHAIN
(TC Approved Tanks)**



FVO-417TR-1

OIL TANK FUEL GAUGE



FVO-416AGTR-1

BATTERY & TRAY/HARNESS



FV-460TR/FV-461TR

115V GFI WEATHERPROOF
CASE & 115V GFI
RECEPTACLE & WEATHER
PROOF CLEAR IN-USE GFI
PVC COVER



FV-454TR-1

FV-455TR-1

FV-455TR-2

DISTRIBUTION PANEL
(PANEL ONLY)



FV-451TR

20AMP BREAKER 2 POLE
15AMP BREAKER 2 POLE



FV-466TR

CONTROL PANEL

MAGNETIC SWITCH



FVO-426TR

TEMPERATURE GAUGE



FVO-425TR

OIL PRESSURE GAUGE



FVO-427TR

VOLT METER



FVO-429TR

HOUR METER



FVO-430TR

IGNITION SWITCH



FVO-428TR

YANMAR PARTS

OIL FILTER - YANMAR



FVO-440TR

FUEL FILTER - YANMAR



FVO-441TR

FUEL SCREEN - YANMAR



FVO-442TR

SLAVE SOLENOID- YANMAR



FVO-443TR

BLOCK HEATER - YANMAR



FVO-444TR

FUEL SOLENOID - YANMAR



FVO-431TR

ANTIFREEZE RESERVOIR -
YANMAR



FVO-445TR

DIODE - YANMAR



FVO-433TR

FAN BELT - YANMAR



FVO-446TR

AIR FILTER - YANMAR



FVO-447TR

ALTERNATOR - YANMAR



FVO-448TR

STARTER - YANMAR



FVO-449TR

KUBOTA PARTS

SOLENOID POWER TIMER - KUBOTA



FVO-450TR

OIL FILTER- KUBOTA



FVO-451TR

FUEL FILTER- KUBOTA



FVO-452TR

FUEL SOLENOID- KUBOTA



FVO-453TR

LIFT PUMP - KUBOTA



FVO-454TR

SLAVE SOLENOID - KUBOTA



FVO-455TR

FAN BELT - KUBOTA



FVO-456TR

AIR FILTER - KUBOTA



FVO-457TR

ALTERNATOR- KUBOTA



FVO-458TR

STARTER - KUBOTA



FVO-459TR

**ANTIFREEZE RESERVOIR -
KUBOTA**



FVO-460TR

**LOW COOLANT LEVEL
SHUTDOWN SWITCH
YANMAR/KUBOTA**



FVO-461TR

HEATER PARTS

HIGH LIMITS



**FV-406 – 250 F
FV-437 - 150 F**

**ADJUSTABLE FAN
LIMIT**



FV-407A

TOGGLE SWITCH



FV-409TR

**POWER
INDICATOR LIGHT**



FV-450

RED LIGHT



FV-411

**THERMOSTAT
CONNECTION**



FV-414B

IGNITION CONTROL



FV0-C700-1029

PHOTO CELL



FV0-20132573

FUEL PUMP



FV0-20136488

FAN MOTOR



FV0-C7001034

ELECTRODE ASSEMBLY



FVO-3005891

OIL NOZZLE



FV-435B 2.00 X 60W
FV-435WC 1.75 X 60W

OIL FILTER- COMPLETE



FVO-418

OIL FILTER INSERT



FVO-419

FAN MOTOR



FV-401TR

FAN BLADE



FV-402TR

FUEL LINES



Please Measure – SUPPLIER HEATER 1
Please Measure – RETURN HEATER 1
Please Measure– SUPPLY TO HEATER 2
Please Measure – RETURN HEATER 2