

OPERATING INSTRUCTIONS MANUAL

(Please retain for future reference)

For

F-400T DUAL FUEL CONSTRUCTION HEATER



CERTIFIED FOR USE IN CANADA AND U.S.A.

As per Standard ANSI Z83.7 2000/

CSA 2.14 2000 Gas Fired Construction Heaters Unvented/Unattended Type.



**FLAGRO INDUSTRIES LIMITED
ST. CATHARINES, ONTARIO
CANADA**

GENERAL HAZARD WARNING:

FAILURE TO COMPLY WITH THE PRECAUTIONS AND INSTRUCTIONS PROVIDED WITH THIS HEATER, CAN RESULT IN DEATH, SERIOUS BODILY INJURY AND PROPERTY LOSS OR DAMAGE FROM HAZARDS OF FIRE, EXPLOSION, BURN, ASPHYXIATION, CARBON MONOXIDE POISONING, AND/OR ELECTRICAL SHOCK.

ONLY PERSONS WHO CAN UNDERSTAND AND FOLLOW THE INSTRUCTIONS SHOULD USE OR SERVICE THIS HEATER.

IF YOU NEED ASSISTANCE OR HEATER INFORMATION SUCH AS AN INSTRUCTIONS MANUAL, LABELS, ETC. CONTACT THE MANUFACTURER.

WARNING:

FIRE, BURN, INHALATION, AND EXPLOSION HAZARD. KEEP SOLID COMBUSTIBLES, SUCH AS BUILDING MATERIALS, PAPER OR CARDBOARD, A SAFE DISTANCE AWAY FROM THE HEATER AS RECOMMENDED BY THE INSTRUCTIONS. NEVER USE THE HEATER IN SPACES WHICH DO OR MAY CONTAIN VOLATILE OR AIRBORNE COMBUSTIBLES, OR PRODUCTS SUCH AS GASOLINE, SOLVENTS, PAINT THINNER, DUST PARTICLES OR UNKNOWN CHEMICALS.

WARNING:

NOT FOR HOME OR RECREATIONAL VEHICLE USE.

WARNING:

INTENDED USE IS PRIMARILY THE TEMPORARY HEATING OF BUILDINGS UNDER CONSTRUCTION, ALTERATION, REPAIR OR EMERGENCIES ONLY.

ALWAYS PROVIDE ADEQUATE VENTILATION. 1 SQ. IN. OF FRESH AIR MUST BE SUPPLIED FOR EVERY 1000 BTUH OF HEAT.

THIS HEATER SHALL BE INSTALLED SUCH THAT IT IS NOT DIRECTLY EXPOSED TO WATER SPRAY, RAIN AND/OR DRIPPING WATER.

This heater is designed and approved for use as a construction heater under ANSI Z83.7 2000 and CSA 2.14 2000 Gas Fired Construction Heaters

We cannot anticipate every use which may be made of our heaters. CHECK WITH YOU LOCAL FIRE SAFETY AUTHORITY IF YOU HAVE QUESTIONS ABOUT APPLICATIONS.

Other standards govern the use of fuel gases and heat producing products in specific applications. Your local authority can advise you about these.

SPECIFICATIONS

Model Number	-	F-400T
Input	-	400,000 btuh
Fuel	-	Natural Gas or Propane
Inlet Pressure	-	Natural Gas: 3.5" W.C. - Propane: 11" W.C.
Ignition	-	Direct Spark Ignition - Thermostat Control
Air Circulation	-	2000 cfm
Fuel Consumption	-	18.5 lbs/hr - 380 cfh
Approved	-	cULus listed

INSTALLATION:

The installation of this heater for use with natural gas shall conform with local codes or, in the absence of codes, with the National Fuel Gas Code ANSI Z223.1/NFPA 54 and the Natural Gas and Propane Installation Code, CSA B149.1.

The installation of this heater for use with propane tank or cylinder shall conform with Local codes or, in the absence of local codes, with the Standard for the Storage and Handling of Liquefied Petroleum Gases, ANSI/NFPA 58 and the Natural Gas and Propane Installation Code, CSA B149.

This heater must be located at least 10ft (3m) from any propane gas cylinder. This heater shall not be directed toward any propane gas container within 20ft (6m).

CLEARANCE TO COMBUSTIBLES:

F-400T TOP: 5 ft FRONT: 8 ft SIDES: 2 ft REAR: 1 ft

CONNECTING THE CYLINDER:

If cylinders are used to supply the heater, no cylinders smaller than 100lb capacity shall be used. These cylinders must supply a vapor withdrawal only.

1. All cylinder connections must be made using a wrench to tighten the POL fitting.
2. Be sure that the cylinder valve is in the closed position when connection or disconnecting the cylinder.
3. A soap and water solution must be applied to all connections in order to leak check the system.

The gas must be turned off at the propane supply cylinder(s) when the heater is not in use. When the heater is to be stored indoors, the connection between the propane supply cylinder(s) and the heater must be disconnected and the cylinders removed from the heater and stored in accordance with Standard for the Storage and Handling of Liquefied Petroleum Gases, ANSI/NFPA 58 and CSA B149.1, Natural Gas and Propane Installation Code.

PIPING: This heater must be installed by a qualified gas technician following local codes published by the authority having jurisdiction. Sizing of supply piping must be determined using the length of pipe run as well as total btuh rating of the appliance(s). Appropriate piping tables must be used to determine size of supply piping dependant

on the length of run from source.

PRESSURES: MAXIMUM INLET PRESSURES: LP: 14.0 IN. WC.
NG: 14.0 IN. WC.

MINIMUM INLET PRESSURES: LP: 11.0 IN. WC.
NG: 3.5 IN. WC.

This heater must be supplied by pressures indicated on the approval label. Over pressure may cause controls to fail.

DO NOT supply this unit with more than ½ psig (14.0 in. W.C.)

Note: A second stage regulator must be installed if the supply pressure exceeds ½ psig.

FUEL: This heater will operate on propane or natural gas. The manifold pressures are listed on the approval label. Ensure that the proper pressure settings are achieved depending on the fuel being used.

A fuel selector valve is located on the manifold of the heater. Ensure that this valve is in the proper position depending on the fuel being used. DO NOT operate the heater with the valve in the incorrect position.

HOSES: All hoses used to connect this heater of fuel supply must be Type 1 approved propane / natural gas hose assemblies.

ELECTRICAL:

WARNING
Electrical Grounding Instructions

This appliance is equipped with a three-prong (grounding) plug for your protection against shock hazard and should be plugged directly into a properly grounded three-prong receptacle.

120v supply must be available. Please note that the motor on this unit requires 15 amps. Ensure appropriate gauge extension cord is used.

MAINTENANCE:

1. Every construction heater should be inspected before each use, and at least annually by a qualified service person.
2. The hose assembly shall be visually inspected prior to each use of the heater. If it is evident there is excessive abrasion or wear, or the hose is cut, it must be replaced prior to the heater being put into operation. The replacement hose assembly shall be that specified by the manufacturer.
3. The appliance must be kept clear and free from combustible materials, gasoline and other flammable vapors and liquids.
4. The flow of combustion and ventilation air must not be obstructed. Be sure to check the fan assembly and ensure that the motor and blade are operating properly.
5. Compressed air should be used to keep components free of dust and dirt build up. Note: Do not use the compressed air inside any piping or regulator components.

F-400T START UP INSTRUCTIONS:

1. Set fuel selector valve according to gas supply to be used

2. Connect construction heater to gas supply with approved hose assembly.

3. Plug the electrical cord into a 15 amp supply.

4. Open all gas supply valves.

5. Depress the main switch to the "START" position. The fan will start and the burner should ignite.

6. Set the Thermostat to the desired temperature.

7. If heater fails to ignite after 3 attempts call your supplier for service.

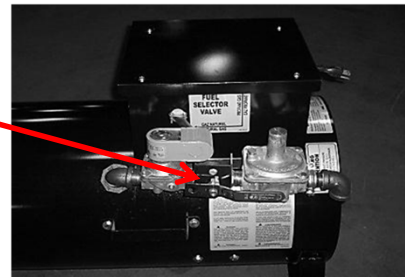

TO SHUT DOWN:

1. Close the main gas supply valve while the heater is operating.

2. Move the main switch to the "OFF" position.

3. Disconnect the heater from gas supply.



F-400T TROUBLESHOOTING ANALYSIS:

PROBLEM: HEATER WILL NOT LIGHT

POSSIBLE CAUSE: Air switch improperly set.

REMEDY: Use centre adjusting screw to set air switch.
Turn clockwise to increase sensitivity, turn counter clockwise to decrease sensitivity.

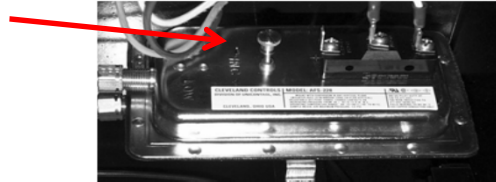

POSSIBLE CAUSE: Blockage in copper inlet tubes.

REMEDY: Disconnect tubes from air switch. Use high pressure air to clean any debris that may block the airflow.

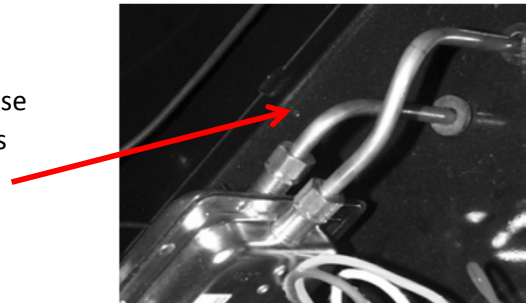

POSSIBLE CAUSE: Faulty Switch.

REMEDY: Replace Switch.

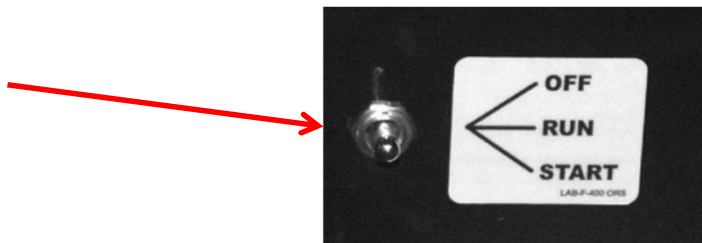

POSSIBLE CAUSE: Rear of heater blocked.

REMEDY: Ensure rear of heater is unobstructed and proper rear clearances are maintained. (see approval label)

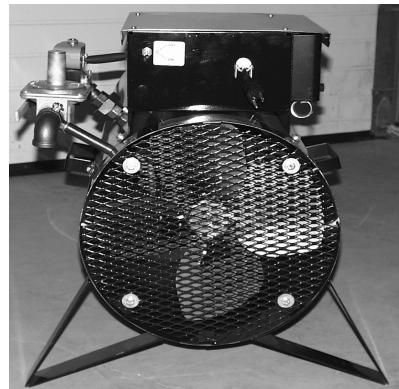

POSSIBLE CAUSE: Faulty Solenoid.

REMEDY: Ensure solenoid is energized.
(use volt meter)

Ensure plunger in the solenoid is being activated. (use manometer at test point after solenoid)
(use volt meter)

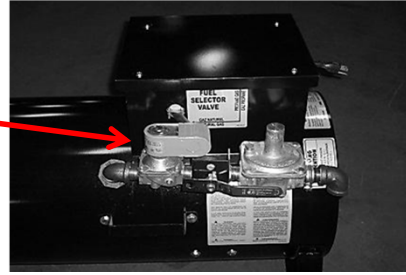

POSSIBLE CAUSE: Incorrect Gas Supply.

REMEDY: Ensure required gas supply pressures are supplied to the heater.
(see approval label)

POSSIBLE CAUSE: Spark Plug.

REMEDY: Ensure gap in spark plug is approx. 3/16".
Check spark plug wire connections.
Ensure spark plug has good spark.
Replace spark plug if necessary.

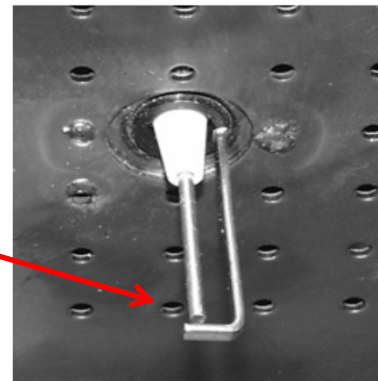

POSSIBLE CAUSE: Ignition Board

REMEDY: Ensure electrical signals for both spark plug and solenoid are present.
(use volt meter)

Ensure ignition board is properly grounded.



POSSIBLE CAUSE: Thermostat.

REMEDY: Ensure the thermostat is calling for heat.

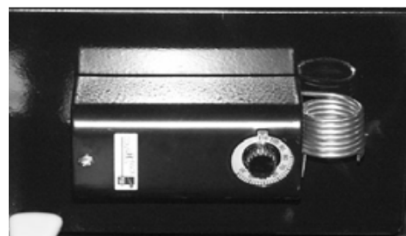

PROBLEM: HEATER WILL NOT REMAIN LIT AFTER START UP

POSSIBLE CAUSE: Faulty flamerod wire.

REMEDY: Check flamerod wire for any damage.

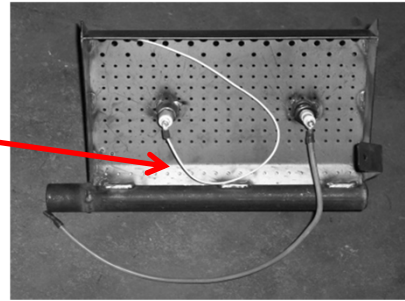

POSSIBLE CAUSE: Faulty flamerod

REMEDY: Ensure connections are secure.
Replace flamerod if necessary.

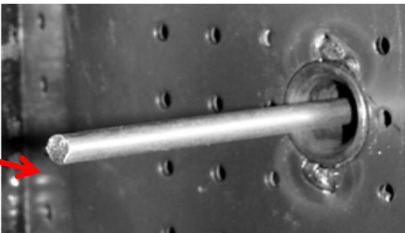

POSSIBLE CAUSE: Ignition Board

REMEDY: Check ground wire for proper connection.
Check polarity of extension cord compared to polarity of plug on heater.
Replace faulty ignition board.



POSSIBLE CAUSE: Thermostat

REMEDY: Ensure the thermostat is calling for heat.

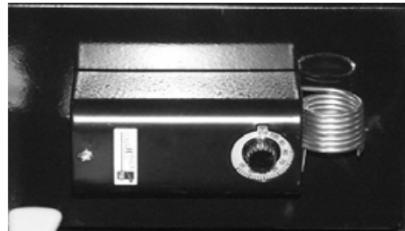

POSSIBLE CAUSE: Electrical - All components

REMEDY: Before replacing an component, all connections must be checked to ensure electrical circuit is complete. (Use volt meter and refer to enclosed wiring diagram)

POSSIBLE CAUSE: Pipe Fittings

REMEDY: When loosened, tightened or replaced, the complete fitting should be removed and approved pipe sealant applied to all male threads before reconnection.

After a heater is serviced, the valve train should be checked for leaks with a soap and water solution or approved leak detector solution.

F-400T Parts List

Main Controls

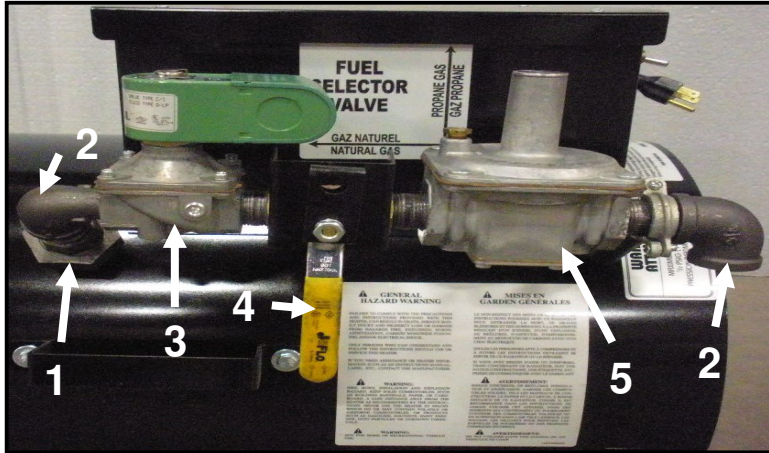

Thermostat Control

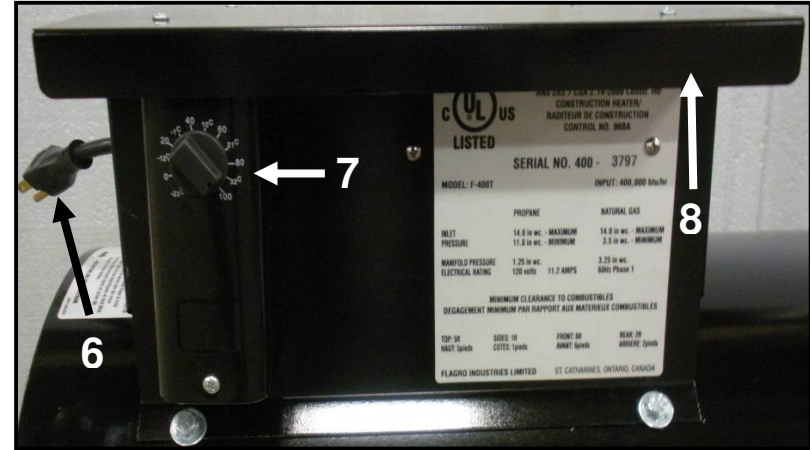

Wiring Components

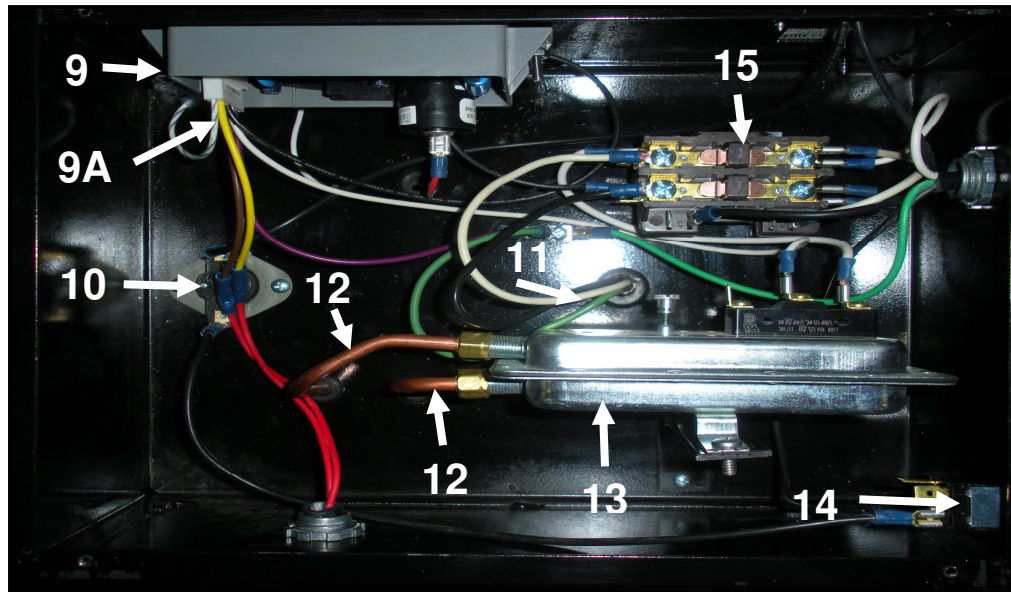

flagro
INDUSTRIES LIMITED

F-400T Parts List

Front

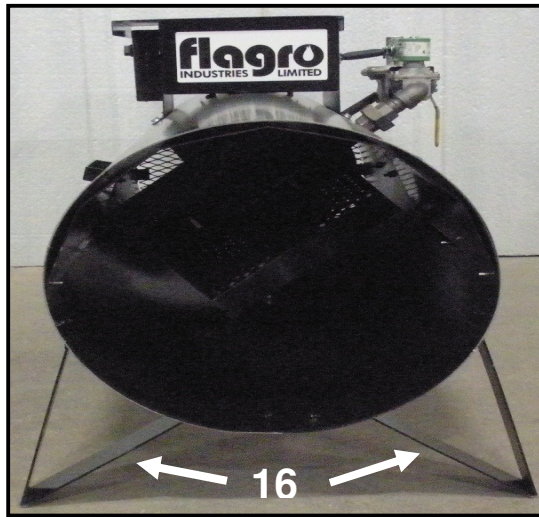

Burner

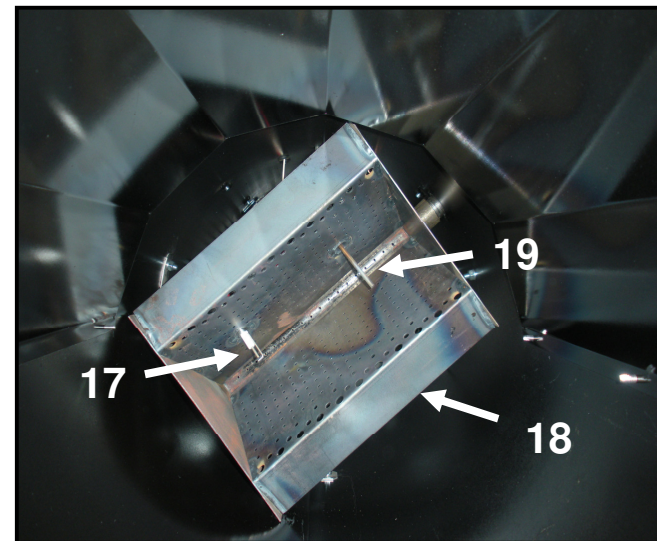

Back

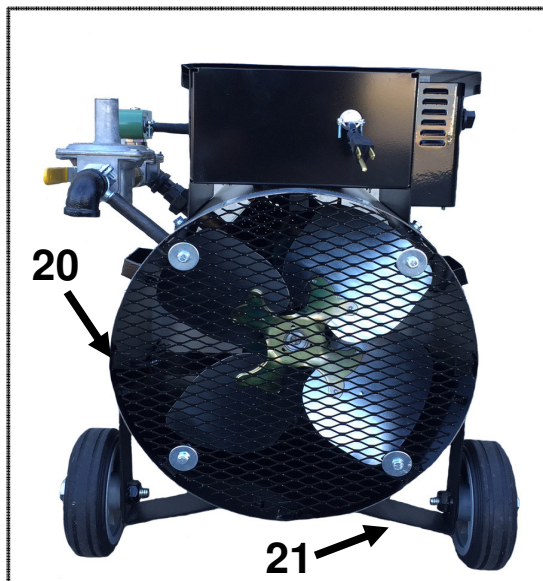

Fan and Motor

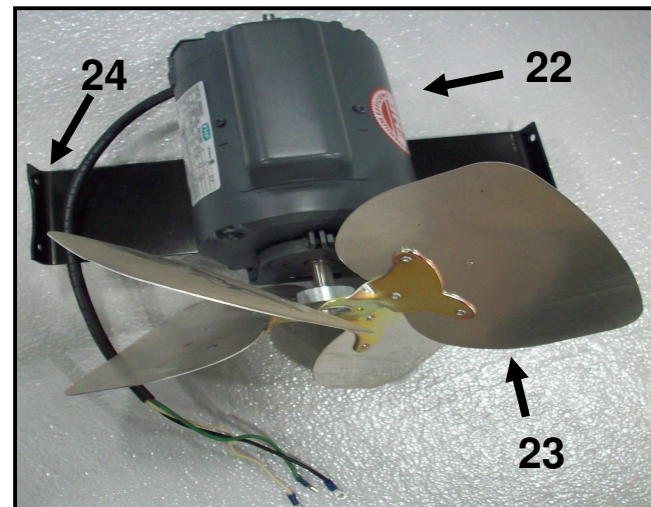

F-400T Parts Numbers

Accessories

<u>Item #</u>	<u>Description</u>	<u>P/N</u>
1	3/4" BM Union	40-104-12
2	3/4" X 90 BM Steel Elbow	40-116-12
3	Solenoid	S-404A
4	Fuel Selector Valve	S-403
5	Regulator	S-402
6	Electrical Cord	S-431
7	Thermostat	S-416
8	Heater Lid	S-430
9	Potted Ignition Control (120V)	S-415P
9A	Wiring Harness	S-415W
10	High Temperature Limit	S-410
11	Flame Rod Wire	S-407A
12	Air Sensing Tubes (2)	S-427
13	Air proving Switch	S-414
14	Off-Run-Start Switch	S-411
15	Main Relay	S-412
16	Front Legs	S-418
17	Long Reach Ignitor	S-408A
18	Burner	S-405
19	Flame Rod	S-406A
20	Screen	S-419
21	Wheel Kit	WK-400
22	1/3 H.P. Motor	S-400
23	Fan Blade	S-401
24	Motor Mount	S-434
25	3/4" X 15-FT Hose Ass.	S52180-12
26	3/4" Second Stage Regulator	B42R0.75
27	3/4" Second Stage Ventless	260SDOPCO
28	3/4" Second Stage Ventless	325-5AL600

Hose Assembly

25



(Custom hose available)

Vented Regulator

26



(max. 20 psi)

Ventless Regulator

27



(max. 10 psi)

Ventless Regulator

28



(max. 5 psi)